

**STRAIGHT PLUG CLAMP TYPE
CABLE 10+11/50+75 S+D**

R161.022.050
SERIES N

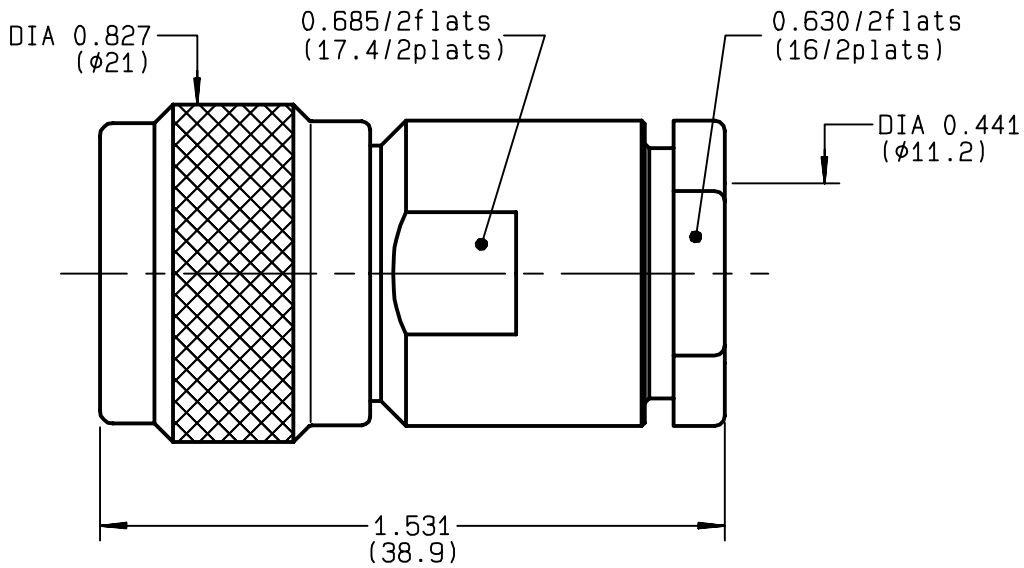

NOMINAL IMPEDANCE	50 Ω	CABLES : KX 4
FREQUENCY RANGE	0-11 GHz	KX 8
TEMPERATURE RATING	-55/+155 °C	RG 11
V.S.W.R	1.30 + x F(GHz)Maxi	RG 144
RF INSERTION LOSS	0.048 √F(GHz) dB Maxi	RG 165
VOLTAGE RATING	1400 Veff Maxi	RG 213
DIELECTRIC WITHSTANDING VOLTAGE	2500 Veff Mini	RG 214
INSULATION RESISTANCE	5000 MΩMini	RG 216
HERMETIC SEAL	NA Atm.cm ³ /s	RG 225
LEAKAGE (pressurized only)	NA	RG 393
MECHANICAL DURABILITY	500 Cycles	OTHERS CHARACTERISTICS
WEIGHT	49.7 gr	CABLE RETENTION 300 N Mini
SPECIFICATION		CENTER CONTACT RETENTION
		Axial force - mating end 68 N Mini
		Axial force - opposite end 68 N Mini
		Torque NA cm.N Mini
		RECOMMENDED TORQUES
		Mating 130 cm.N
		Panel nut NA cm.N
		Clamp nut 800 cm.N

CONNECTOR PARTS	MATERIALS	FINISH (all values are given in micrometers)
BODY	BRASS	BLACK-CHROMIUM 0.2 OVER NICKEL 2
OUTER CONTACT	BRASS	BBR 2
CENTER CONTACT	BRASS	GOLD 0.5 OVER NICKEL 2
INSULATOR	PTFE	-
GASKET	SILICONE RUBBER	-
OTHERS PIECES	BRASS	BLACK-CHROMIUM 0.2 OVER NICKEL 2

ISSUE 9809F02	CREATION DATE 06/05/1993	FILE PART-NUMBER EPC 96-07
-------------------------	------------------------------------	--------------------------------------



BONOMINI

The information given here is subject to change without notice.
Design changes may be in order to improve the product .

Connect to the future



R161.022.050

ISSUE 9809F02 SERIES N

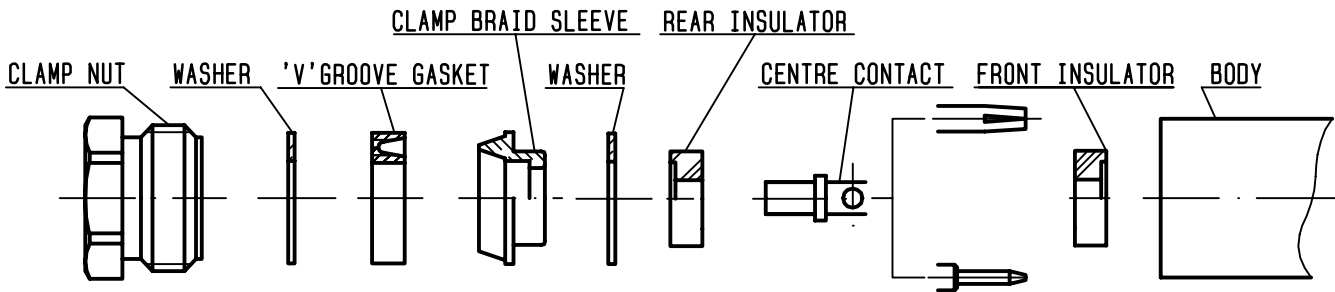

①

Strip the cable .
-
-
-

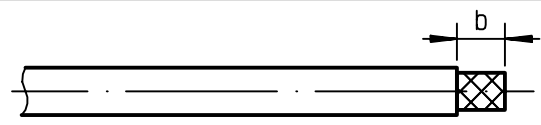

Stripping	a	b	c	d	e
inch	0.197	0.335	0	0	0.059
mm	5	8.5			1.5

②

Slide the clamp nut , the washer and the 'V'groove gasket onto the cable .
Slide clamp braid sleeve over braid .
Fold back braid and trim off surplus braid .
Trim back dielectric as shown .

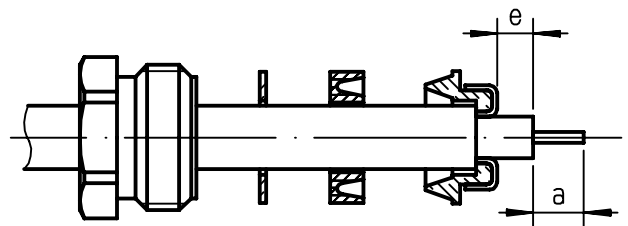

③

Mount washer and rear insulator .
Solder the cable inner conductor into centre contact .
-
-
-

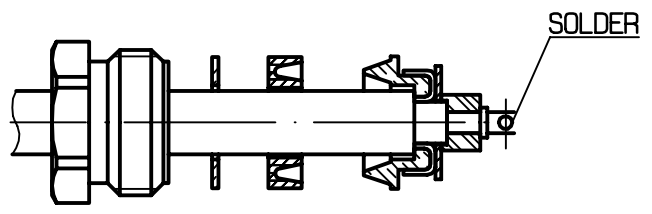

④

Mount front insulator .
Screw sub-assembly into the connector body .
(recommended coupling torque 70.87 in.lb)
-

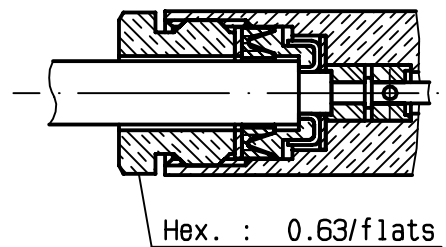

BONOMINI